

CARACTERISTICAS / FEATURES

Material hormigón Petra 1
Acabado decapado e hidrofugado
Dimensiones l. 50, a. 50, h. 45 cm
Color ver carta de colores
Fijación apoyado por su propio peso o con varilla metálica
Peso 350 Kg
Palet 110 x 110 cm (2 unidades)

Material precast concrete Petra 1
Finish scaled and waterproofed
Dimensions l.50, w.50, h. 45 cm
Colour see colour catalogue
Fixing resting on the ground or with metal rod
Weight 350 Kg
Pallet 110 x 110 cm (2 units)

dineñador / design: magourban

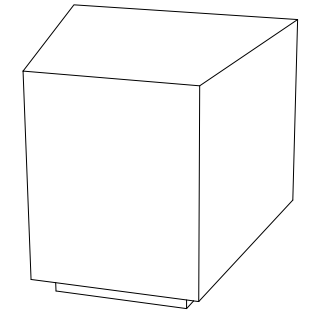

DYNAMIC SERP

GEOMETRIA / GEOMETRY

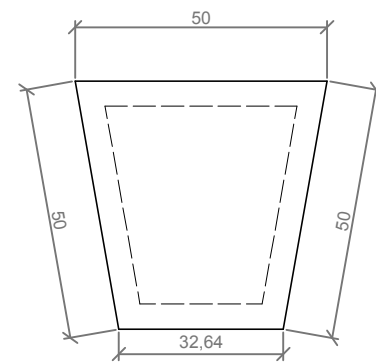

PLANTA / TOP VIEW

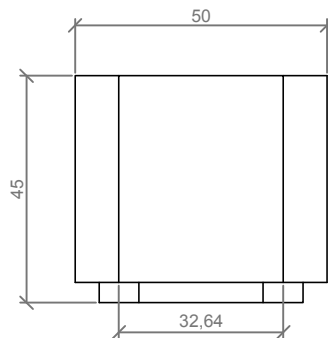

ALZADO / FRONT VIEW

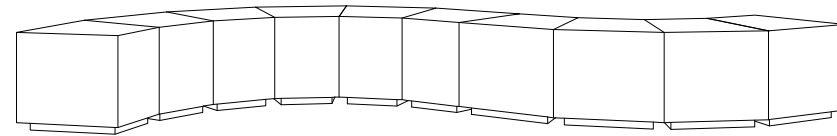

ESC.: 1/15

MANIPULACIÓN E INSTALACIÓN / HANDLING AND INSTALLATION

Elevación / Hoisting
 P= 350 Kg

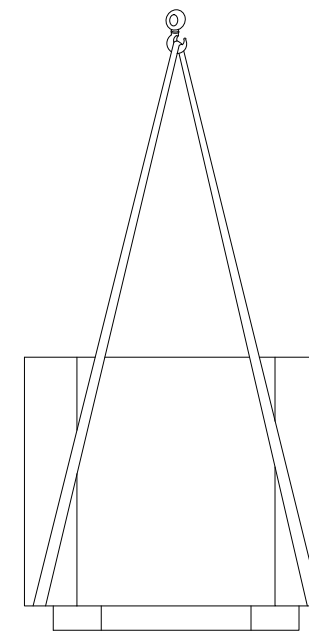

ESPECIFICACIONES / SPECIFICATIONS

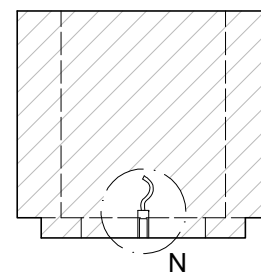

SECCIÓN A-A' / SECTION A-A'

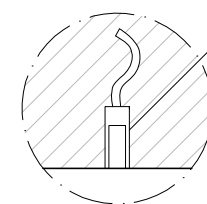

DETALLE N / DETAIL N

Poliestireno expandido (EPS)
 Expanded polystyrene (EPS)

Tárrega, Lleida - Tel. +34 973 15 87 03 - www.magourban.com - info@magourban.com

magourban



ESC.: 1/15