

CARACTERÍSTICAS / FEATURES

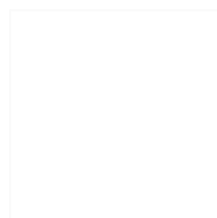

Material hormigón SMC
Acabado decapado e hidrofugado
Dimensiones l. 200, a. 90, h. 75 cm (mesa)
 l. 200, a. 30, h. 45 cm (banqueta)
Color ver carta de colores
Fijación apoyado por su propio peso o con varillas metálicas
Peso 150 Kg (mesa)
 70 kg (banqueta)
 270 kg (mesa+banqueta+pallet)
Palet 210 x 200 cm

Material precast concrete SMC
Finish etched and waterproofed
Dimensions l. 200, w. 90, h. 75 cm (table)
 l. 200, w. 90, h. 75 cm (bench)
Colour see colour catalogue
Fixing resting on the ground or with metal rod
Weight 150 Kg (table)
 70 kg (bench)
 270 kg (table+bench+pallet)
Pallet 210 x 200 cm

diseñador / design: magourban

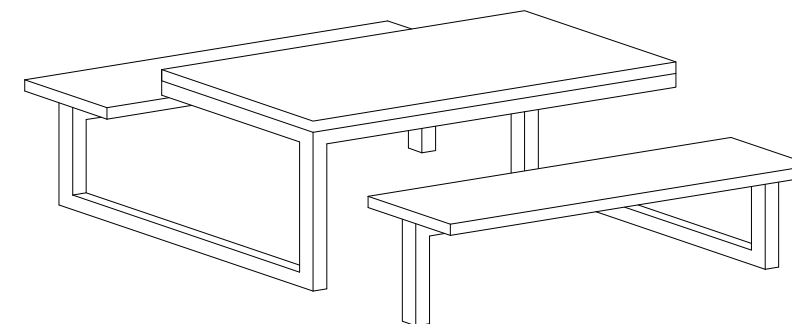

PICNIC LOOP

GEOMETRIA / GEOMETRY

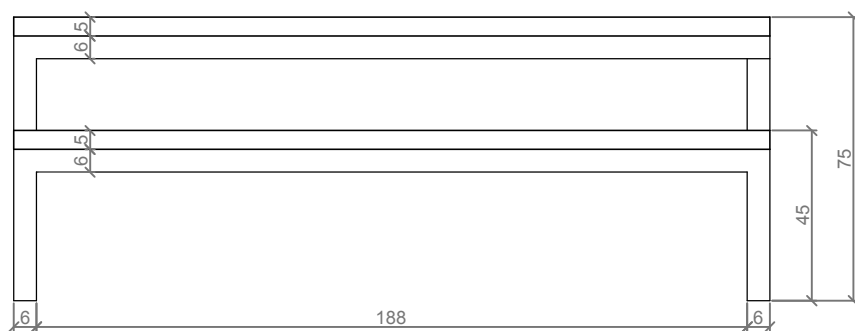

ALZADO / FRONT VIEW

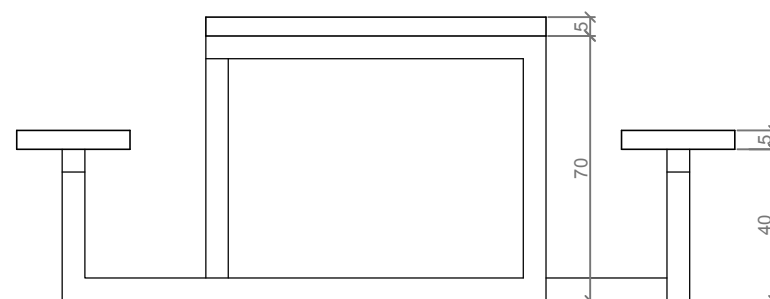

PERFIL / PROFILE SIDE

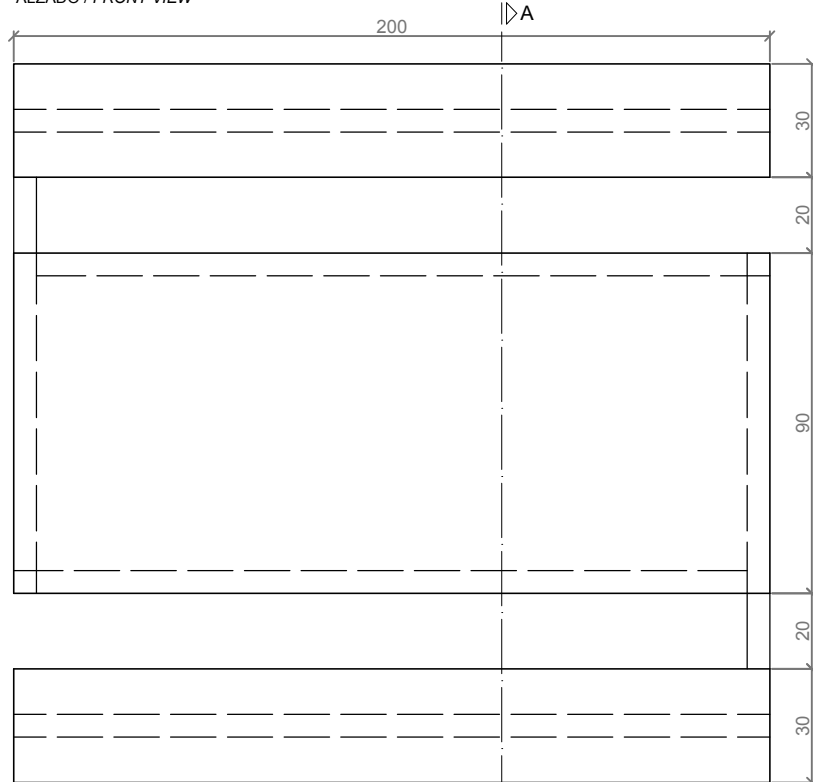

PLANTA / TOP VIEW

ESC. 1:20

MANIPULACIÓN E INSTALACIÓN / HANDLING AND INSTALLATION

- 1 Instalar la estructura metálica en el sitio deseado / Install the metal frame in the desired location

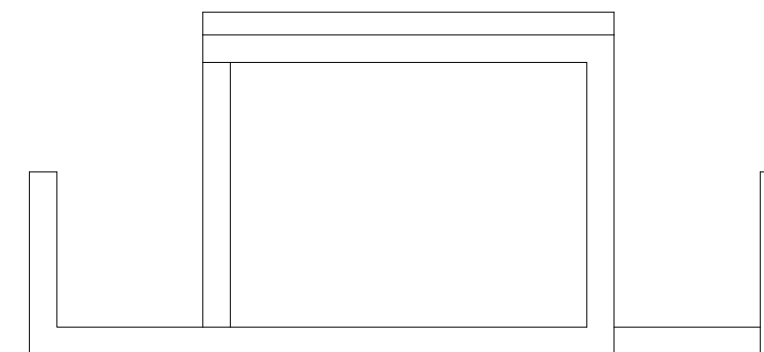

- 2 Montar las losas de los banquillos / Assemble the bench slabs

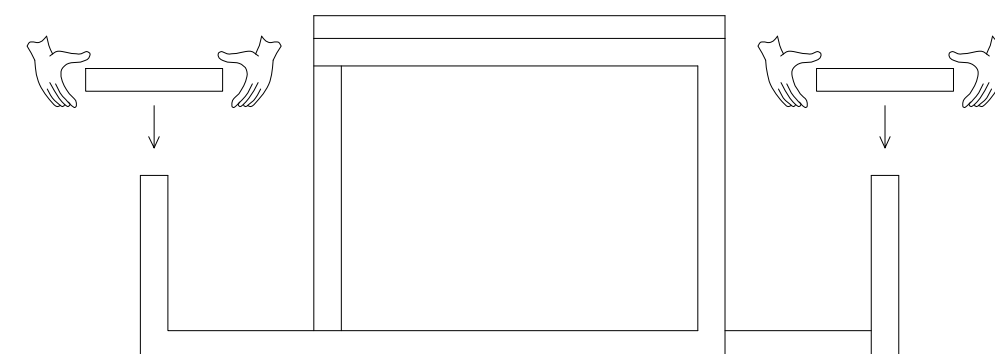

ESPECIFICACIONES / SPECIFICATIONS

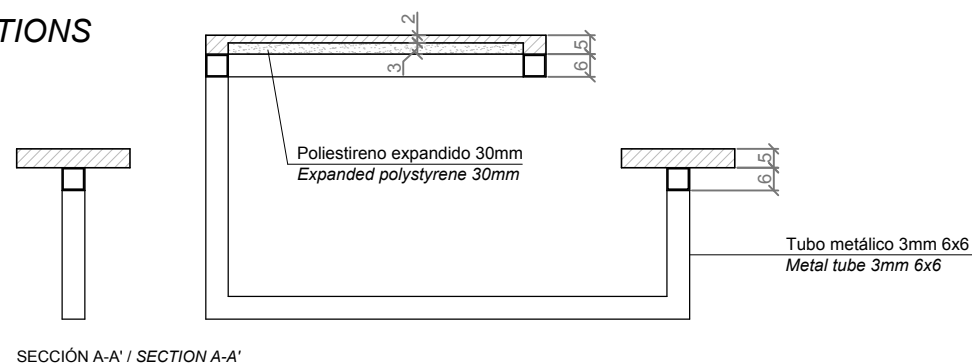

SECCIÓN A-A' / SECTION A-A'