

CARACTERÍSTICAS / FEATURES



Material hormigón Petra 1
Acabado decapado e hidrofugado
Dimensiones l. 100, a. 100, h. 90 cm
Color ver carta de colores
Fijación apoyado por su propio peso
Peso c/palet 660 Kg / 620 L
Palet 110 x 110 cm

Material precast concrete Petra 1
Finish etched and waterproofed
Dimensions l. 100, w. 100, h. 90 cm
Colour see colour catalogue
Fixing resting on the ground
Weight with pallet 660 Kg / 620 L
Pallet 110 x 110 cm

diseñador / design: Ton Riera

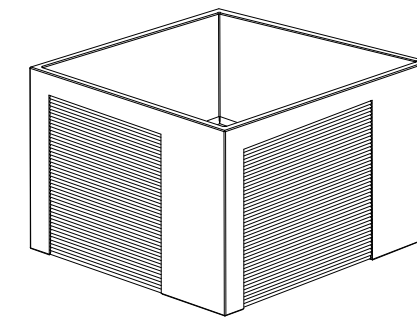

TANIT SP

GEOMETRIA / GEOMETRY

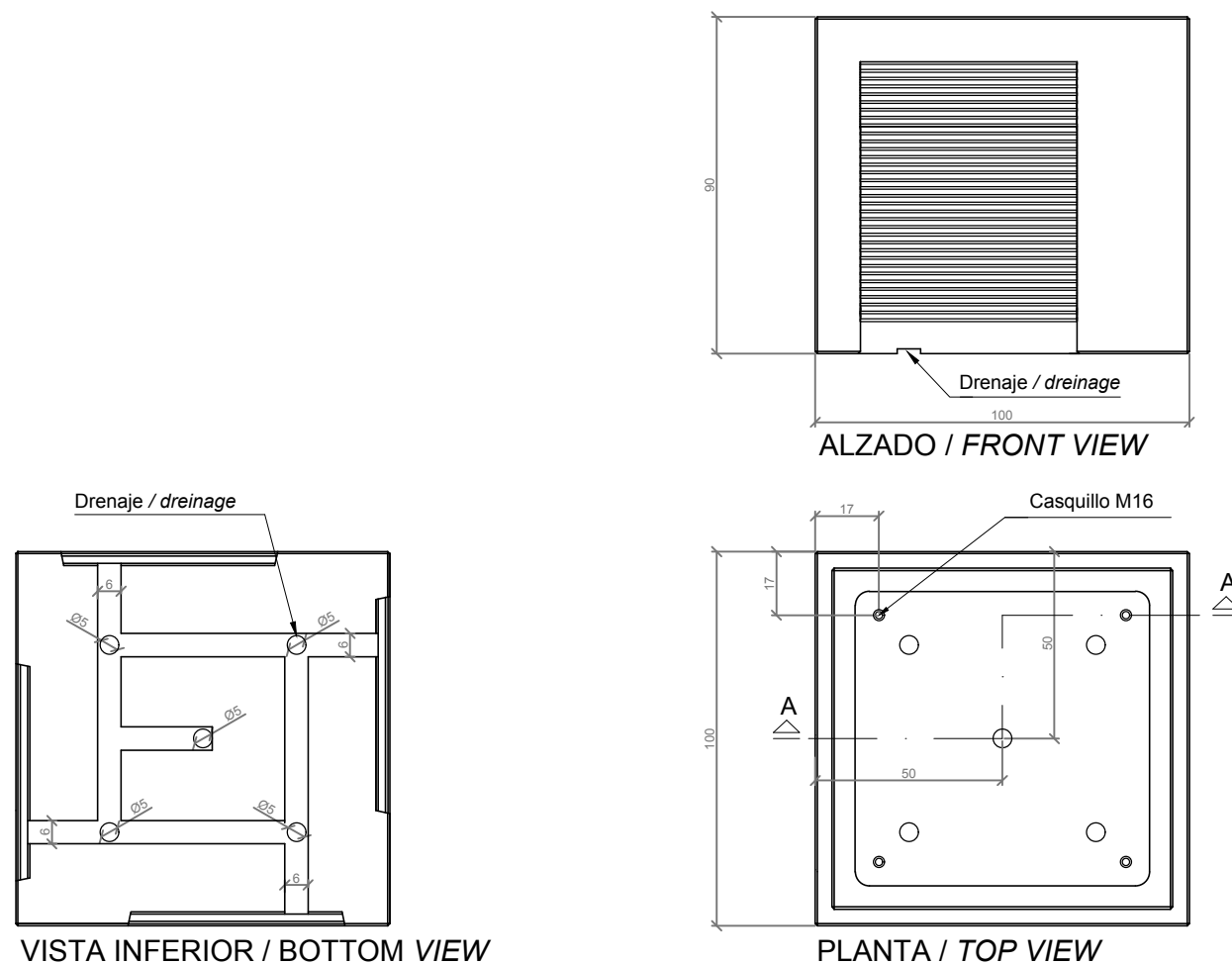

ESC. 1:20

MANIPULACIÓN E INSTALACIÓN / HANDLING AND INSTALLATION

1 Enroscar cáncamo al casquillo roscado
 Thread the eyebolt on the thread sleeve

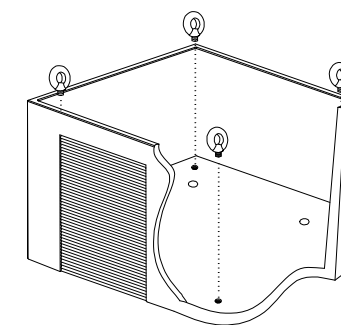

2 Elevar mediante eslingas / Lifting with slings

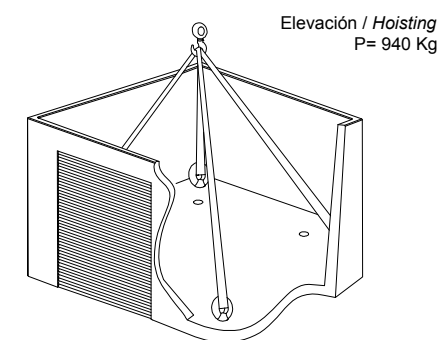

3 Verter resina epoxy / Pour resin epoxy

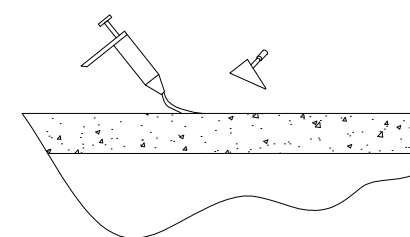

4 Instalar sobre la resina epoxy / Install over resin epoxy

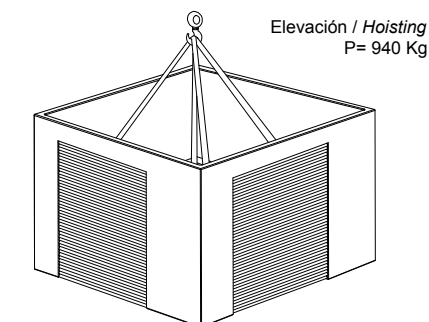

ESPECIFICACIONES / SPECIFICATIONS

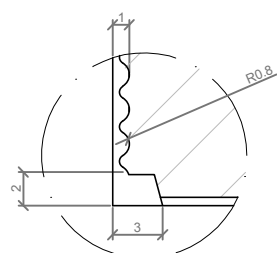

DETALLE N / DETAIL N

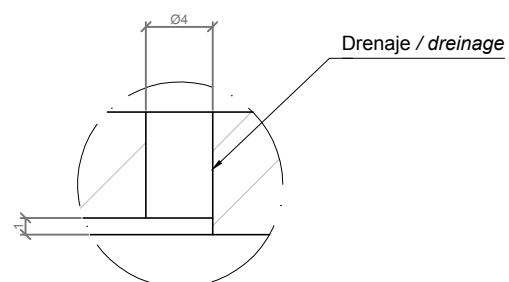

DETALLE M / DETAIL M

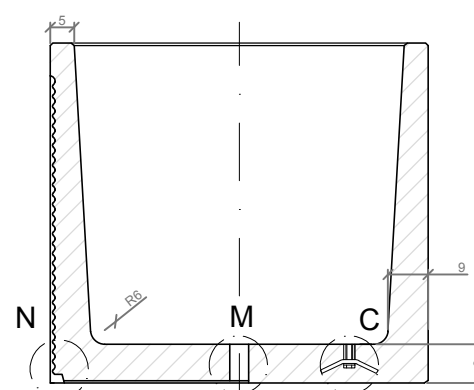

SECCIÓN A-A' / SECTION A-A'

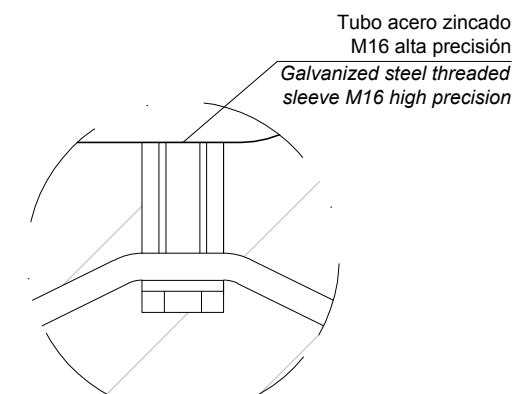

DETALLE C / DETAIL C

Tubo acero zincado
 M16 alta precisión
 Galvanized steel threaded
 sleeve M16 high precision