

CARACTERÍSTICAS / FEATURES

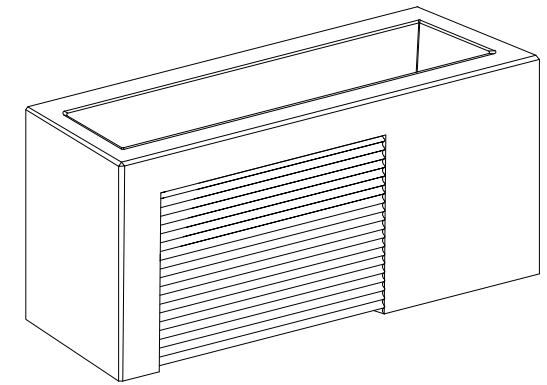

Material hormigón Petra 1
Acabado decapado e hidrofugado
Dimensiones l. 140, a. 42, h. 60 cm
Color ver carta de colores
Fijación apoyado por su propio peso o mediante resina epoxi
Peso 350 Kg / 145 L
Palet 160 x 55 cm

Material precast concrete Petra 1
Finish etched and waterproofed
Dimensions l. 140, w. 42, h. 60 cm
Colour see colour catalogue
Fixing resting on the ground or with epoxy resin
Weight 350 Kg / 145 L
Pallet 160 x 55cm



diseñador / design: Ton Riera

TANIT S

GEOMETRIA / GEOMETRY

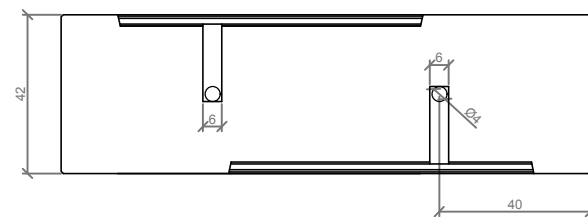

VISTA INFERIOR / BOTTOM VIEW

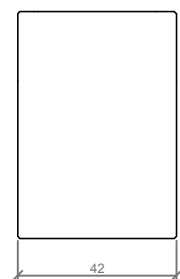

PERFIL / RIGHT SIDE

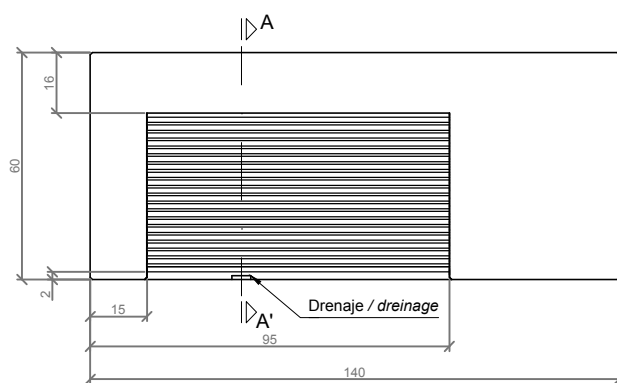

ALZADO / FRONT VIEW

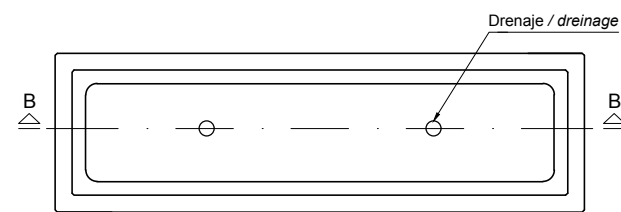

PLANTA / TOP VIEW

ESC. 1:20

MANIPULACIÓN E INSTALACIÓN / HANDLING AND INSTALLATION

- 1 Verter resina epoxy / Pour resin epoxy

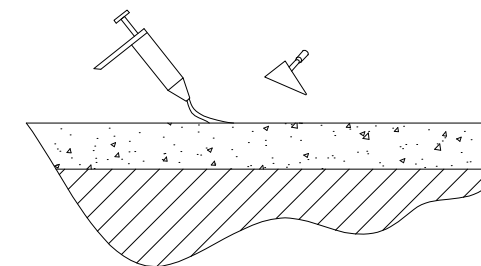

- 2 Elevar mediante eslingas e instalar sobre la resina epoxy / Lifting with slings and install over resin epoxy

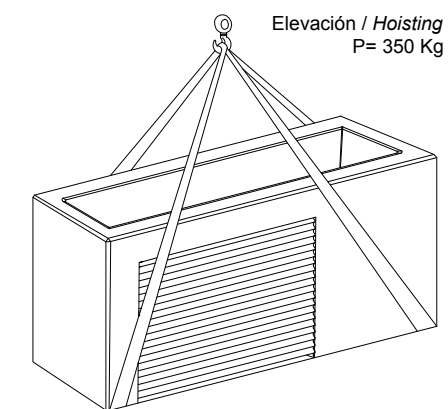

ESPECIFICACIONES / SPECIFICATIONS

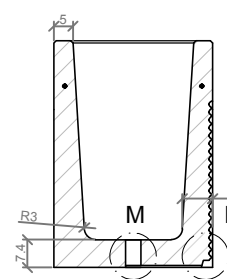

SECCIÓN A-A' / SECTION A-A'

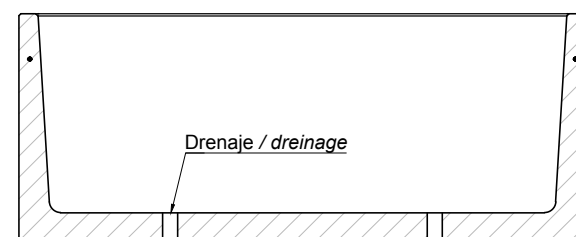

SECCIÓN B-B' / SECTION B-B'

Armadura Ø8 - 1350 x 370 mm
 Armour Ø8 - 1350 x 370 mm

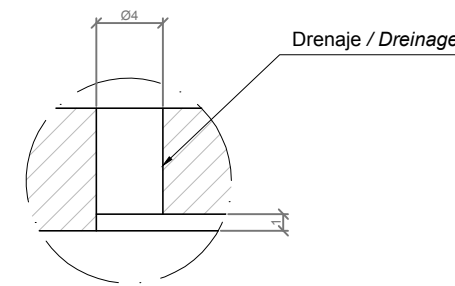

DETALLE M / DETAIL M

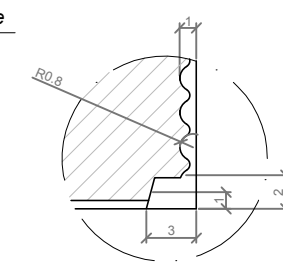

DETALLE N / DETAIL N