

CARACTERÍSTICAS / FEATURES

Material hormigón Petra 1
Acabado decapado e hidrofugado
Dimensiones l. 100, a. 86,6, h. 45 cm
Color ver carta de colores
Fijación apoyado por su propio peso
Peso 700 Kg
Palet 120 x 100 cm (2 unidades)

Material precast concrete Petra 1
Finish scaled and waterproofed
Dimensions l. 100, w. 86,6, h. 45 cm
Colour see colour catalogue
Fixing resting on the ground by its own weight
Weight 700 Kg
Pallet 120 x 100 cm (2 units)

diseñador / design: magourban

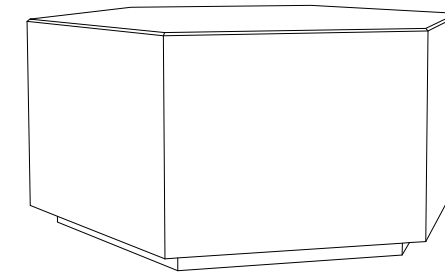

DYNAMIC SIX

GEOMETRIA / GEOMETRY

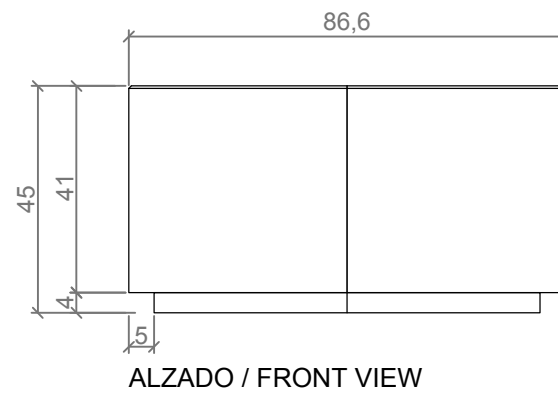
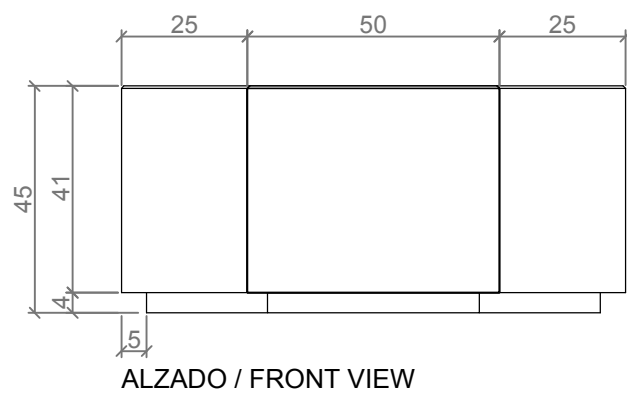
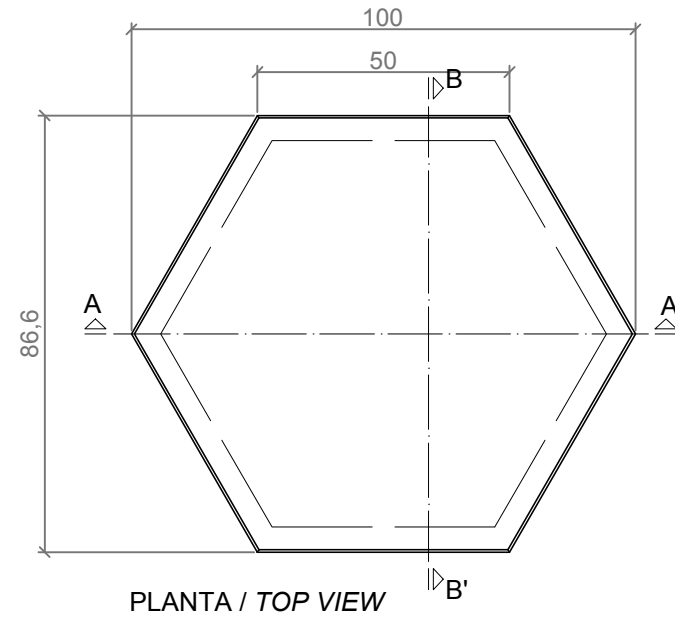

ESC.: 1/15

MANIPULACIÓN E INSTALACIÓN / HANDLING AND INSTALLATION

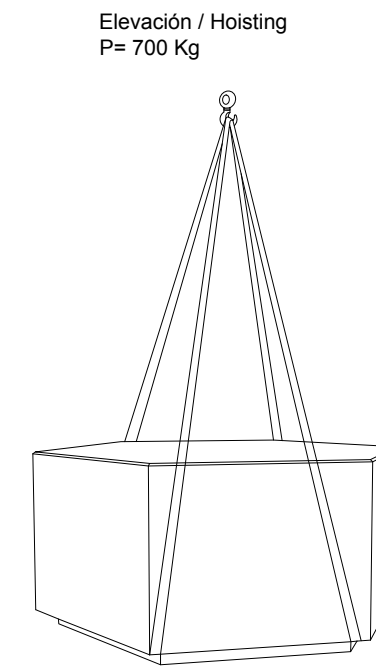

ESPECIFICACIONES / SPECIFICATIONS

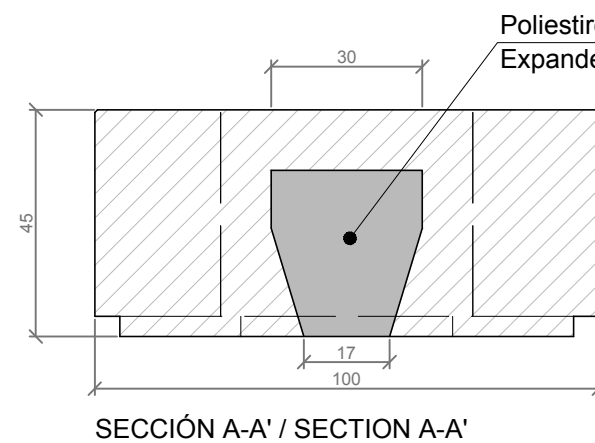

Poliestireno expandido (EPS)
Expanded polystyrene (EPS)

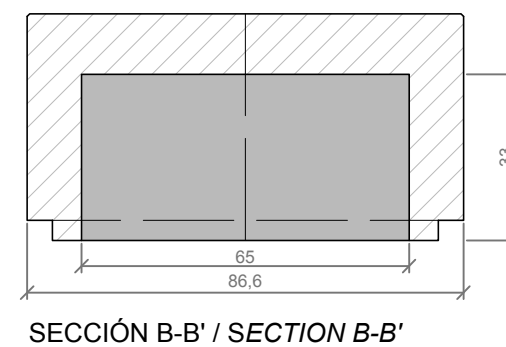

ESC.: 1/15