

CARACTERÍSTICAS / FEATURES

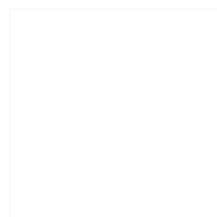

Material hormigón Petra 1
Acabado decapado e hidrofugado
Dimensiones l. 164, a. 61, h. 47 cm
Color ver carta de colores
Fijación apoyado por su propio peso o mediante resina epoxi
Peso 450 Kg
Palet 170 x 70 cm

Material precast concrete Petra 1
Finish scaled and waterproofed
Dimensions l. 164, w. 61, h. 47 cm
Colour see colour catalogue
Fixing resting on the ground or with epoxy resin
Weight 450 Kg
Pallet 170 x 70 cm

diseñador / design: Roger Albero

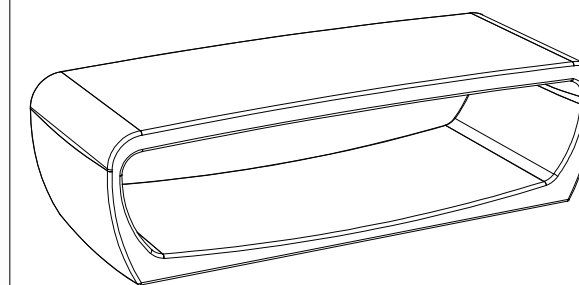

TUBE BANCA

GEOMETRIA / GEOMETRY

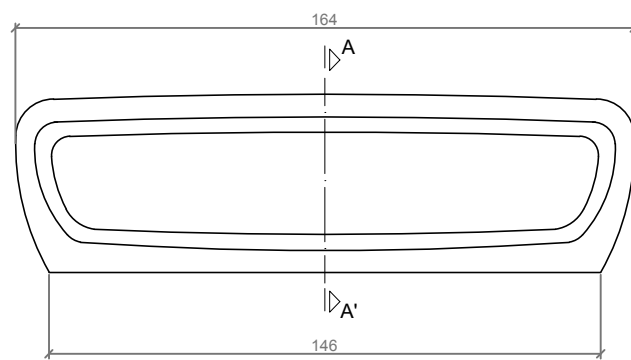

ALZADO / FRONT VIEW

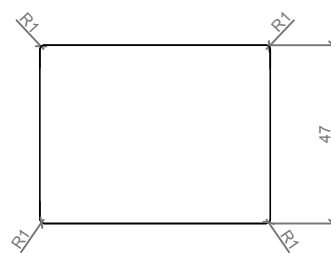

PERFIL / PROFILE

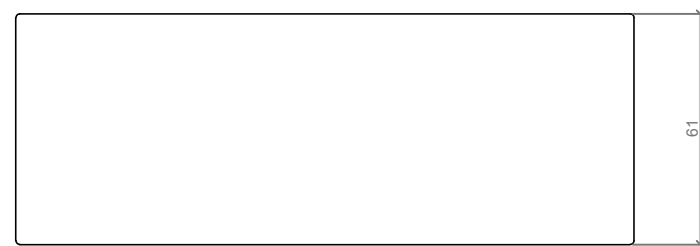

PLANTA / TOP VIEW

ESC. 1:20

MANIPULACIÓN E INSTALACIÓN / HANDLING AND INSTALLATION

- 1 Verter resina epoxy / Pour resin epoxy

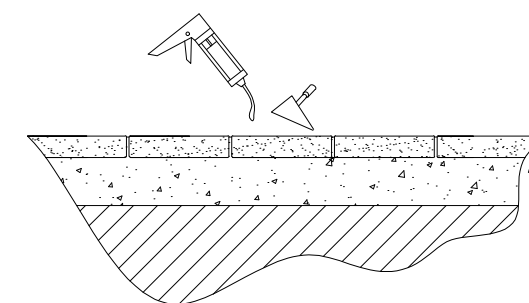

- 2 Elevar mediante eslingas para instalar / Lift with slings for install

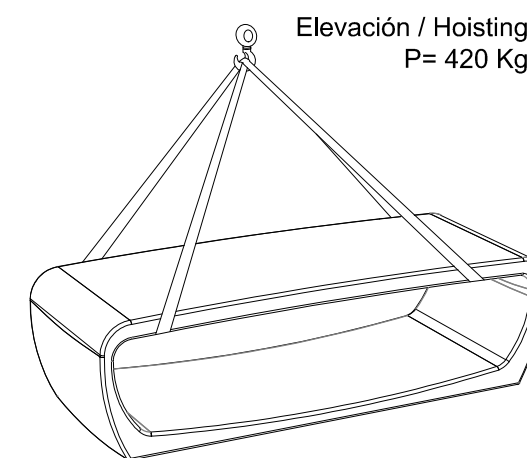

ESPECIFICACIONES / SPECIFICATIONS

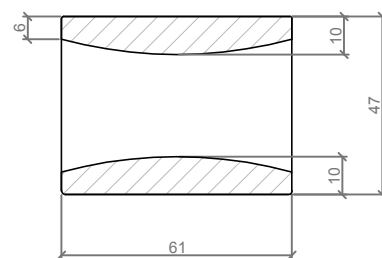

SECCIÓN A-A' / SECTION A-A'