

## CARACTERÍSTICAS / FEATURES

**Material** hormigón Petra 1 + madera  
**Acabado** decapado e hidrofugado + barnizado  
**Dimensiones** l. 200, a. 65, h. 78 cm  
**Color** ver carta de colores  
**Fijación** mediante varillas metálicas  
**Peso** 115 Kg  
**Palet** 220 x 80 cm

**Material** precast concrete Petra 1 + wood  
**Finish** scaled and waterproofed + varnished  
**Dimensions** l. 200, w. 65, h. 78 cm  
**Colour** see colour catalogue  
**Fixing** by metal rods  
**Weight** 115 Kg  
**Pallet** 220 x 80 cm

diseñador / design: magourban

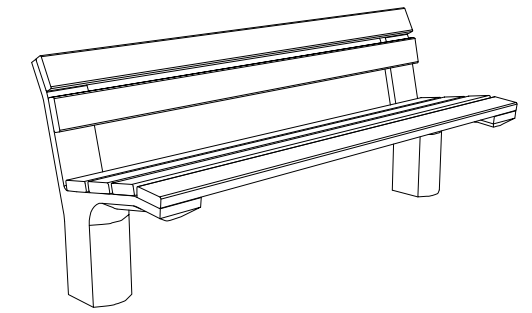

UNIT (pine wood)

## GEOMETRIA / GEOMETRY

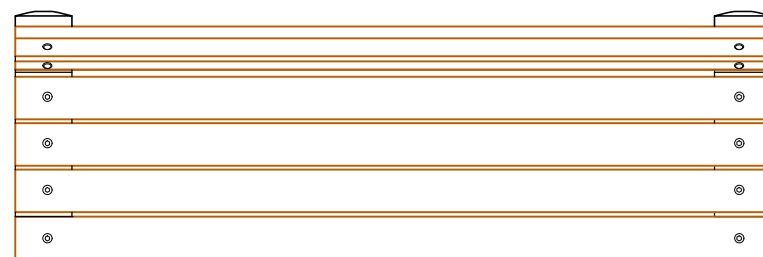
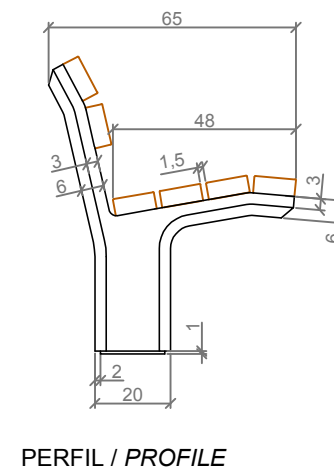
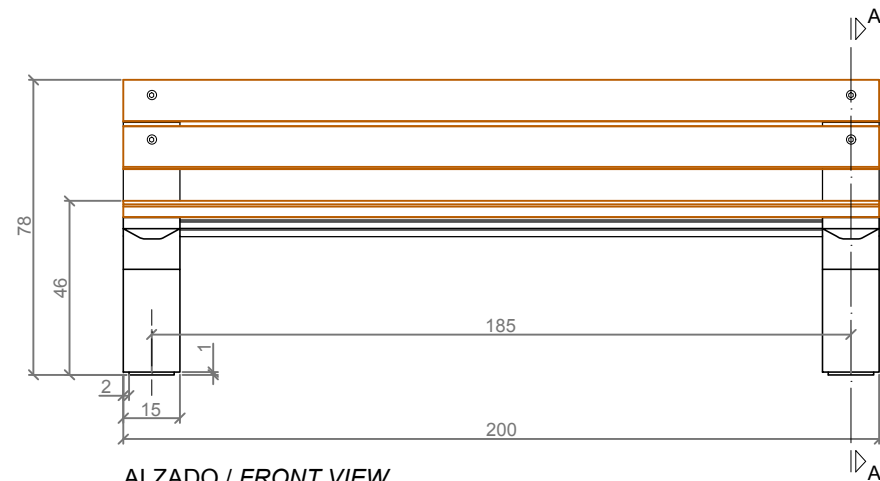

ESC. 1:20

## MANIPULACIÓN E INSTALACIÓN / HANDLING AND INSTALLATION

- 1 Instalar madera y fijar tornillos  
Install wood & tightening screwings

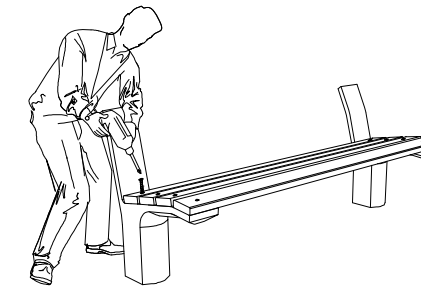

- 2 Perforar 2 agujeros entre Ø20-Ø22 a una distancia de 185 cm  
Drill 2 holes between Ø20-Ø22 at a distance of 185 cm

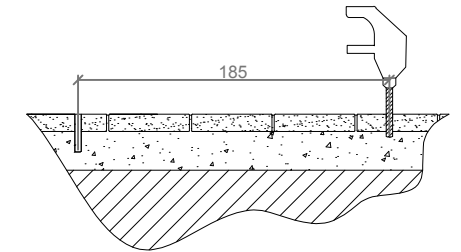

- 3 Elevar el banco mediante eslingas y roscar las varillas de fijación  
Raise the bench with slings and thread the fixing rods

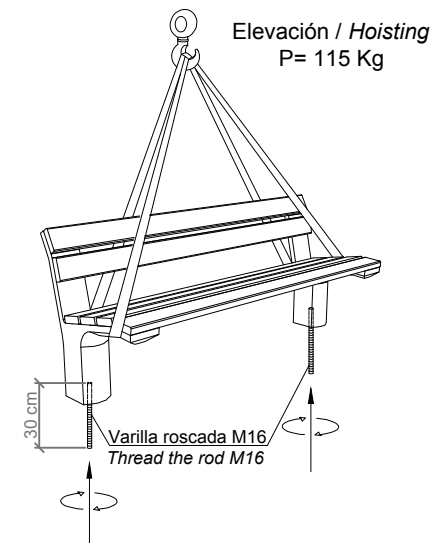

- 4 Verter RESINA EPOXY en los agujeros y también con cuidado en la base de los pies del banco e instalar  
Pour EPOXY RESIN into the holes and carefully too at the base of the feet of the bench and install

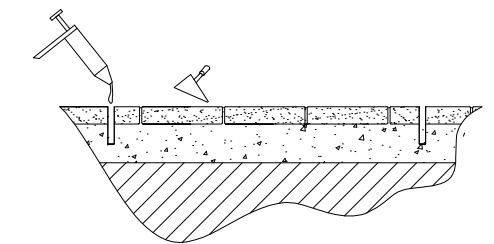

## ESPECIFICACIONES / SPECIFICATIONS

