

CARACTERÍSTICAS / FEATURES



Material hormigón Petra 1
Acabado decapado e hidrofugado
Dimensiones l. 150, a. 81, h. 89 cm
Color ver carta de colores
Fijación apoyado por su propio peso
Peso 831 Kg / 600 L
Palet 200 x 85 cm

Material precast concrete Petra 1
Finish etched and waterproofed
Dimensions l. 150, w. 81, h. 89 cm
Colour see colour catalogue
Fixing resting on the ground
Weight 831 Kg / 600 L
Pallet 200 x 85 cm

diseñador / design: Ton Riera

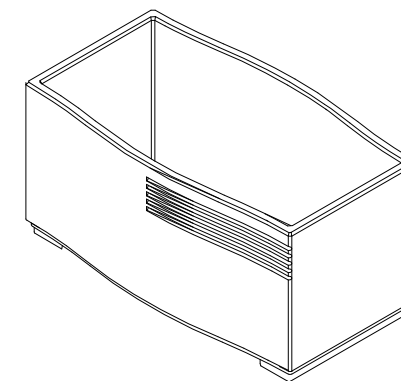

FUAT S-85P

GEOMETRIA / GEOMETRY

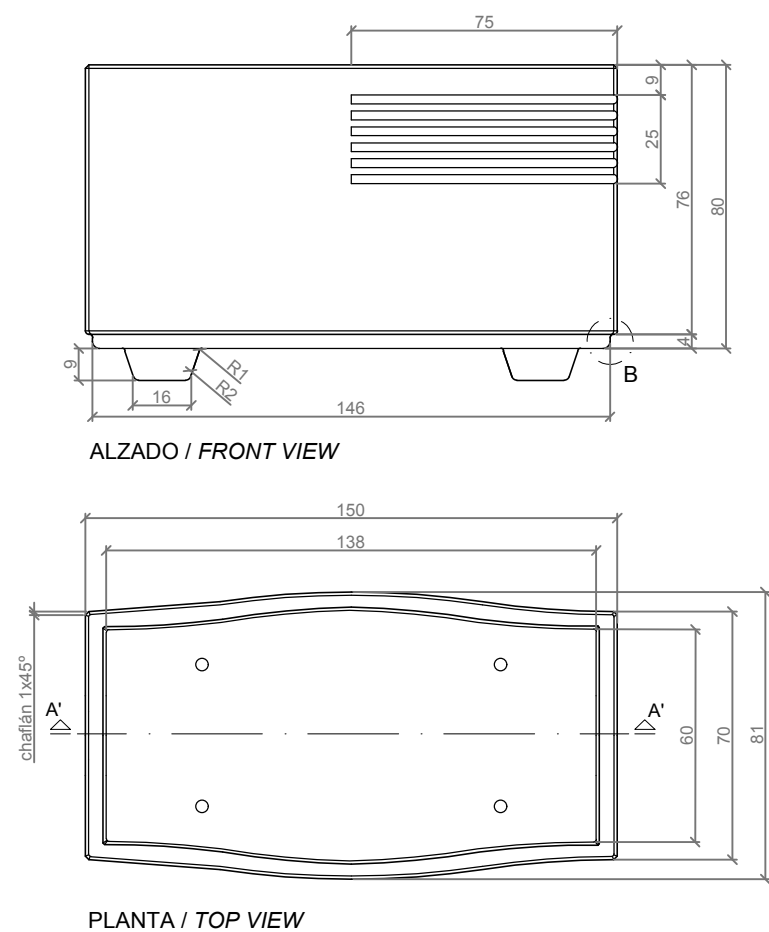

ESC. 1:20

MANIPULACIÓN E INSTALACIÓN / HANDLING AND INSTALLATION

- 1 Fijar eslingas e instalar / Fixing slings and install.

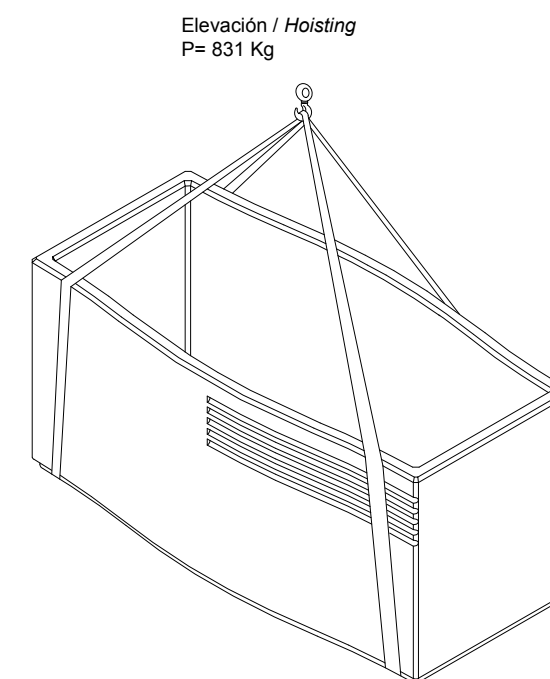

ESPECIFICACIONES / SPECIFICATIONS

