

Design: Renata Paunoch
Year: 2015

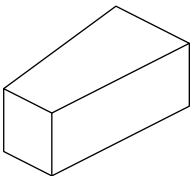

ELEMENTS

CRO-A1



CRO-A2

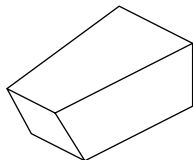

CRO-A3

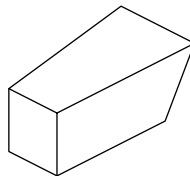

CRO-C1

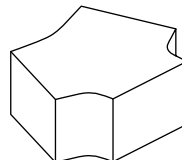

CRO-C2

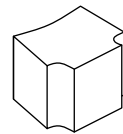

SAMPLE COMBINATIONS

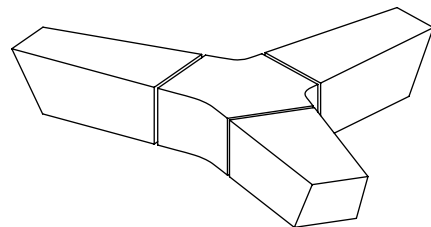
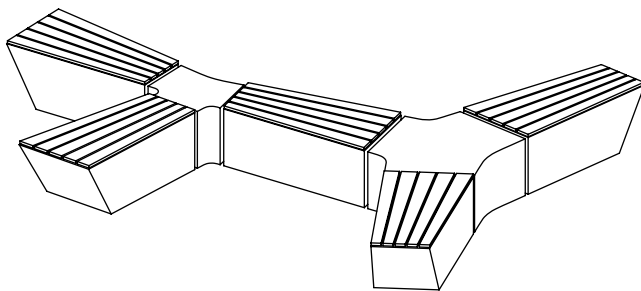

Design: Renata Paunoch
Year: 2015

INFO

Material:	high performance concrete (HPC)
Standard colour:	white
Finish:	natural cast
Treatment:	impregnated
Seat:	varnished ash/ oiled ash
Lifting:	with lifting straps
Placement:	on load-bearing, ready-to-use walking surface
Fixing:	with antifreeze adhesive/ by anchoring
Cleaning:	with neutral detergent



MEASUREMENTS

0  500 mm

CRO-A1
380 kg

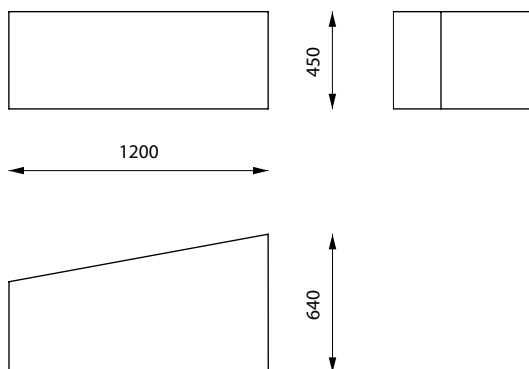

CRO-A1-W
390 kg

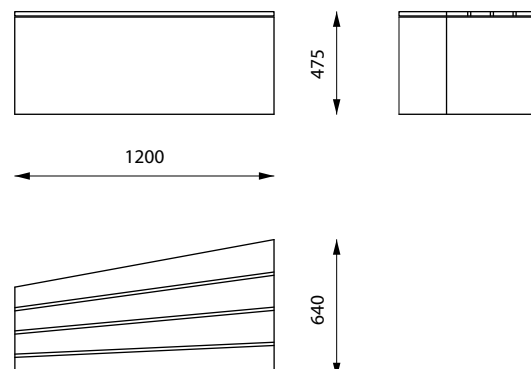

INSTALLATION

The product may be lifted with lifting straps. The product is fixed with antifreeze adhesive or with anchor bolts to load-bearing walking surface.

For further information see Installation Guide.

MAINTENANCE

The product may be cleaned with neutral detergent. For further information see Maintenance Guide.

Design: Renata Paunoch
Year: 2015

INFO

Material:	high performance concrete (HPC)
Standard colour:	white
Finish:	natural cast
Treatment:	impregnated
Seat:	varnished ash/ oiled ash
Lifting:	with lifting straps
Placement:	on load-bearing, ready-to-use walking surface
Fixing:	with antifreeze adhesive/ by anchoring
Cleaning:	with neutral detergent



MEASUREMENTS

0 500 mm

CRO-A2
330 kg

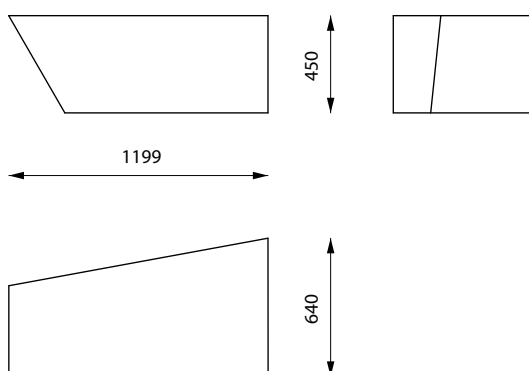

CRO-A2-W
340 kg

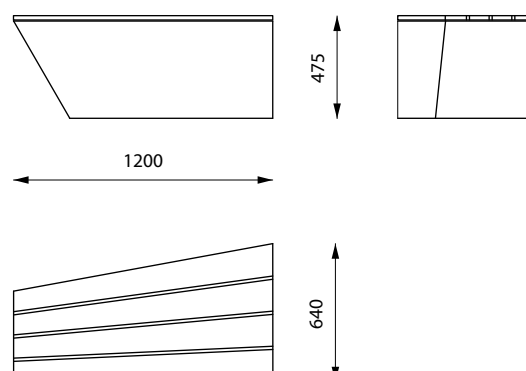

INSTALLATION

The product may be lifted with lifting straps. The product is fixed with antifreeze adhesive or with anchor bolts to load-bearing walking surface.

For further information see Installation Guide.

MAINTENANCE

The product may be cleaned with neutral detergent. For further information see Maintenance Guide.

Design: Renata Paunoch
Year: 2015

INFO

Material:	high performance concrete (HPC)
Standard colour:	white
Finish:	natural cast
Treatment:	impregnated
Seat:	varnished ash/ oiled ash
Lifting:	with lifting straps
Placement:	on load-bearing, ready-to-use walking surface
Fixing:	with antifreeze adhesive/ by anchoring
Cleaning:	with neutral detergent



MEASUREMENTS

0  500 mm

CRO-A3
315 kg

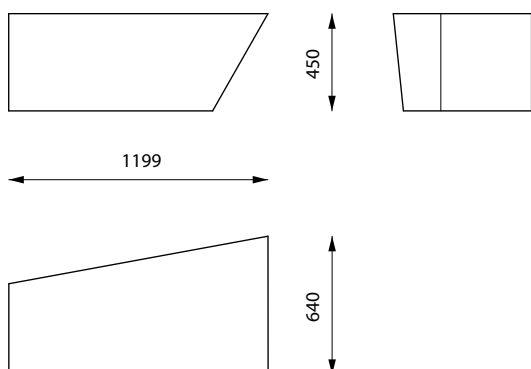

CRO-A3-W
325 kg

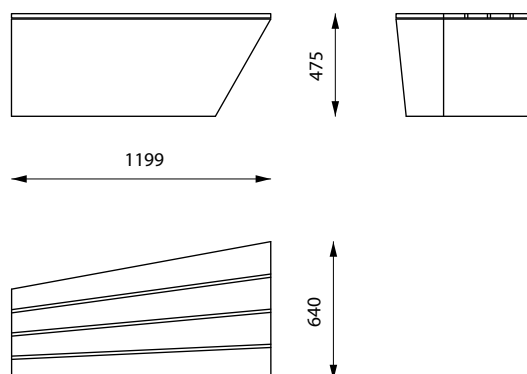

INSTALLATION

The product may be lifted with lifting straps. The product is fixed with antifreeze adhesive or with anchor bolts to load-bearing walking surface.

For further information see Installation Guide.

MAINTENANCE

The product may be cleaned with neutral detergent. For further information see Maintenance Guide.

Design: Renata Paunoch

Year: 2015

INFO

Material:	high performance concrete (HPC)
Standard colour:	white
Finish:	natural cast
Treatment:	impregnated
Lifting:	with lifting straps
Placement:	on load-bearing, ready-to-use walking surface
Fixing:	with antifreeze adhesive/ by anchoring
Cleaning:	with neutral detergent



MEASUREMENTS

0 500 mm

CRO-C1

380 kg

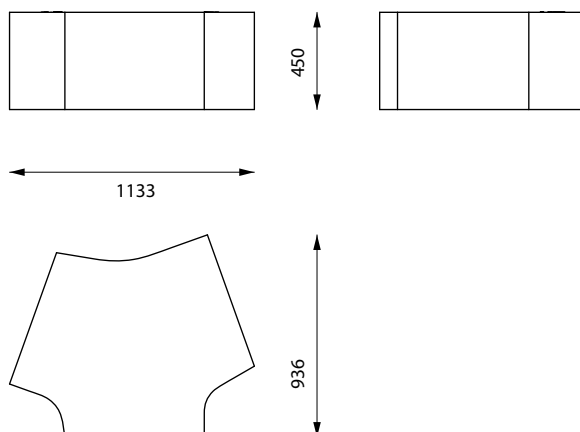

CRO-C2

195 kg

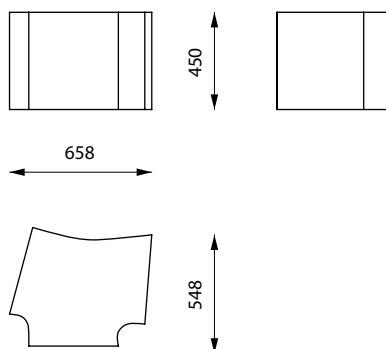

INSTALLATION

The product may be lifted with lifting straps. The product is fixed with antifreeze adhesive or with anchor bolts to load-bearing walking surface.

For further information see Installation Guide.

MAINTENANCE

The product may be cleaned with neutral detergent. For further information see Maintenance Guide.