

Design: Mark Nagy-Mihaly

Year: 2019



## ELEMENTS

TRK-L

TRK-S

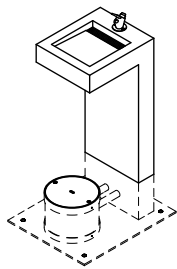
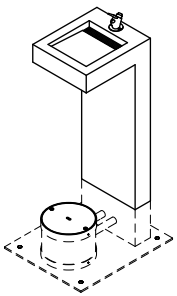

## SAMPLE COMBINATIONS

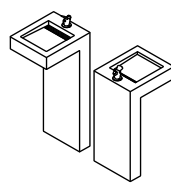
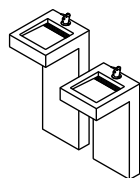
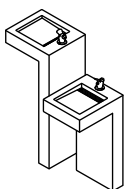
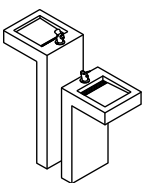

Design: Mark Nagy-Mihaly

Year: 2019

## INFO

Material:	high performance concrete (HPC)
Standard colour:	white
Finish:	natural cast
Treatment:	impregnated
Lifting:	with lifting straps
Placement:	on concrete foundation
Fixing:	by anchoring
Water outlet:	Ø32 PVC pipe
Water inlet:	R 1/2" - min. 3 bar
Cleaning:	with neutral detergent



## MEASUREMENTS

0  500 mm

TRK-L

135 kg

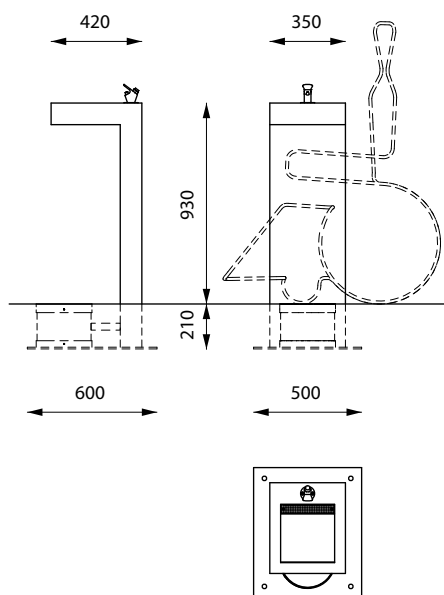

TRK-S

120 kg

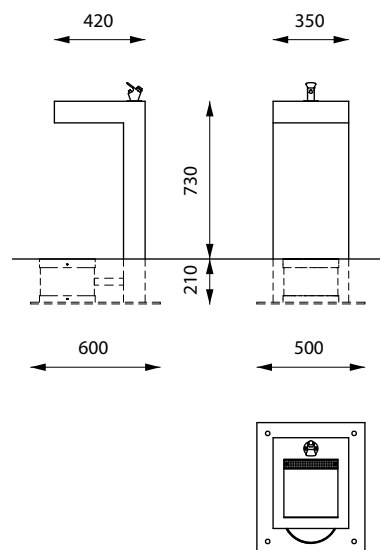

## INSTALLATION

The product may be lifted with lifting straps. The product is fixed with anchor bolts to concrete foundation.

For further information see Installation Guide.

## MAINTENANCE

The product may be cleaned with neutral detergent.

For further information see Maintenance Guide.